

# Woodpeckers®

## SLAB FLATTENING MILL•PRO

O W N E R ' S M A N U A L

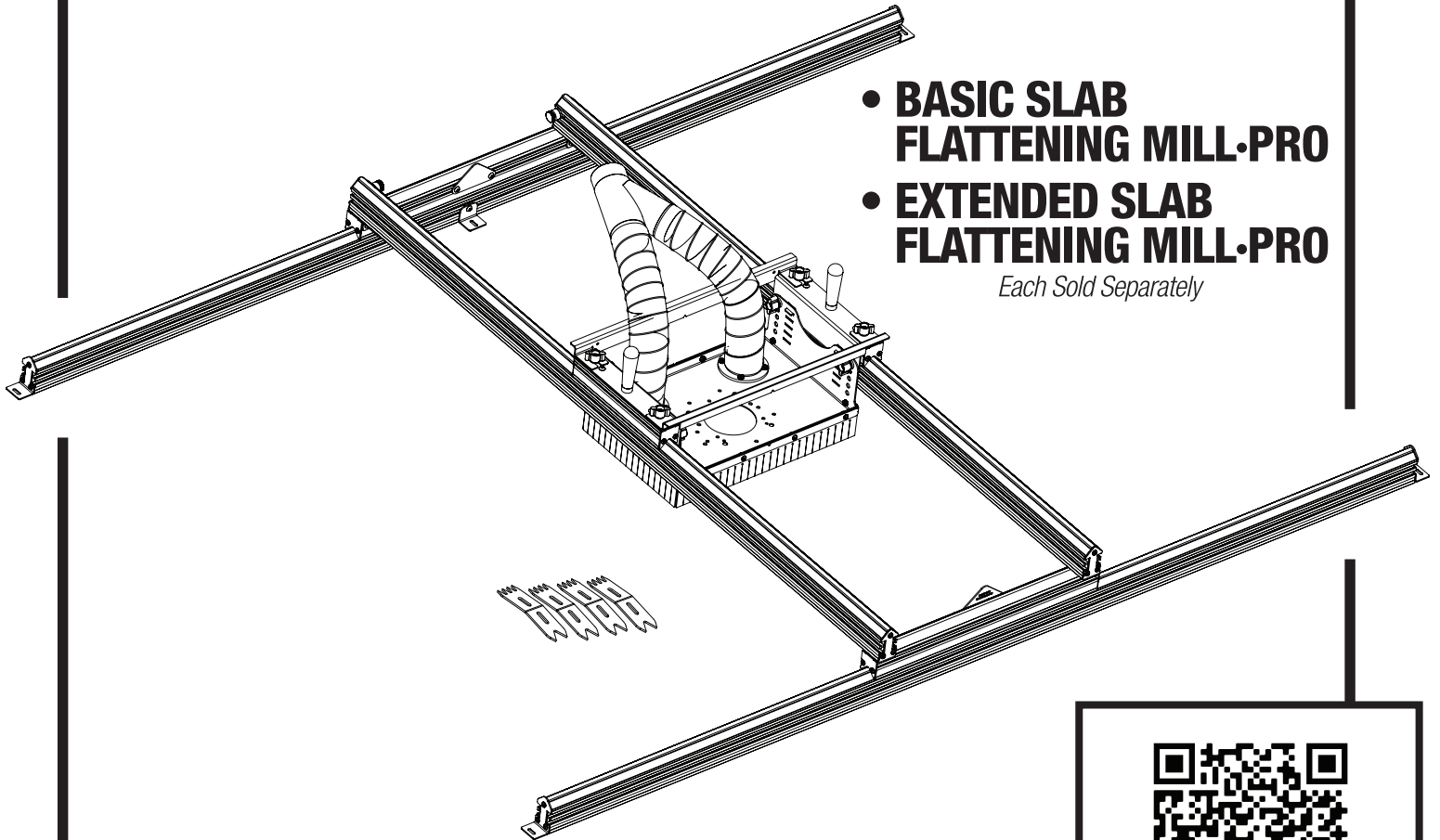

- **BASIC SLAB FLATTENING MILL•PRO**
- **EXTENDED SLAB FLATTENING MILL•PRO**

*Each Sold Separately*

- **CONVERSION KIT SLAB FLATTENING MILL**

*Not Shown - Sold Separately - See Page 7*



Scan the QR code above to watch the video or visit [woodpeck.com](http://woodpeck.com) under the video tab towards the bottom of the product page.

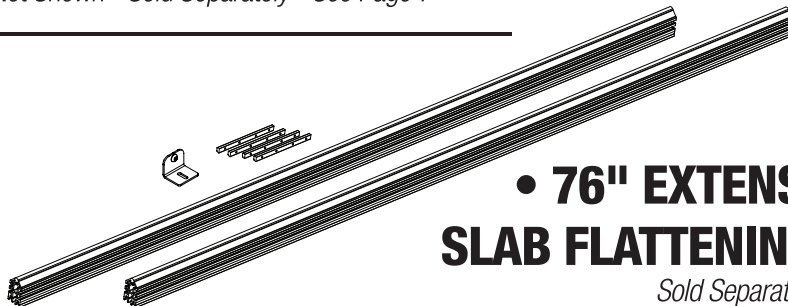

- **76" EXTENSION KIT SLAB FLATTENING MILL•PRO**

*Sold Separately*

If you think you're missing anything, email us at [mailroom@woodpeck.com](mailto:mailroom@woodpeck.com).  
You can also call us at 800-752-0725 from 9:00 a.m. to 5:00 p.m. EST Monday - Friday.

ITEM NO.	DESCRIPTION	QTY.
①*	Short V-Rail 59"	2
②*	Long V-Rail 76"	2
Optional ③*	V-Rails Extended Slab Flattening Mill-PRO	2
Optional ④*	V-Rail Connectors Extended Slab Flattening Mill-PRO	4
⑤	Short Guide Block (Red Anodized Aluminum)	2
⑥	Long Guide Block (Red Anodized Aluminum)	2
⑦	Router Carriage	1
⑧	Router Carriage Hanger	2
⑨	Roll of UHMW Tape	1
⑩	Cross Brace	2
⑪	Long Curtain Retainer	2
⑫	Short Curtain Retainer	2
⑬	Long Vinyl Curtain	2
⑭	Short Vinyl Curtain	2
⑮*	Clamp Dog	4
⑯	2.5" Dust Port	2
⑰	"Y" Hose Connector	1
⑱	2.5" Dust Hose	2
⑲	Hose Clamps	4

### Hardware Bag A

A-1	Pan Head Screw 10-32 x 7/16"	22
A-2	Kep Nut 10-32	22

### Hardware Bag B

B-1	Button Head Hex Screw 1/4-20 x 1"	8
B-2	Button Head Hex Screw 1/4-20 x 1-1/2"	4
B-3	Button Head Hex Screw 1/4-20 x 5/8"	8
B-4	Nyloc Nut 1/4-20	12
B-N/A	5/32" Hex Key For use with all Hex Screws	1

### Hardware Bag C

C-1	Button Head Hex Screw 1/4-20 x 1/2"	4
-----	-------------------------------------	---

### Hardware Bag D

D-1	Safety Stop	2
D-2	Button Head Hex Screw 1/4-20 x 5/8"	4
D-3	Nyloc Nut 1/4-20	4

ITEM NO.	DESCRIPTION	QTY.
----------	-------------	------

### Hardware Bag - E

E-1	Thread Forming Screw Pan Head 10-32 x 1/2"	40
E-N/A	T25 Torx Bit For use with all torx screws	1

### Hardware Bag F

F-1	Black Nylon Washer 3/4"	2
F-2	White Nylon Washer 3/4"	2
F-3	Oval Nut 1/4-20	2
F-4	Black Knob 1/4-20 x 3/4"	2

### Hardware Bag G

G-1*	Tapered Handle	2
G-2*	Black Nylon Washer	2
G-3*	Hex Head Bolt 1/4-20 x 1-1/2"	2

### Hardware Bag H

H-1	Red Wing Knob 1/4-20 Nut	4
H-2	Red Wing Knob with Threaded Extension 1/4-20 x 3/4"	4
H-3	White Nylon Washer 3/4"OD	4

### Hardware Bag I

I-1	Oval Nut 1/4-20	9
-----	-----------------	---

### Hardware Bag J *Extended Slab Flattening Mill-PRO has 2 Hardware Bag J*

J-1	Oval Nut 1/4-20	1
J-2	Button Head Hex Screw 1/4-20 x 3/8"	1
J-3	V-Rail Center Support	1
J-4	Pan Head Screw #10 x 3/4"	1

### Hardware Bag K

K-1	Cross-Rail Gusset	4
-----	-------------------	---

### Hardware Bag L

L-1*	V-Rail End Cap	4
------	----------------	---

### Hardware Bag M

M-1*	V-Rail Mounting End Cap	4
------	-------------------------	---

### Hardware Bag N

N-1*	Guide Block End Cap	8
------	---------------------	---

### Hardware Bag O

O-1	Pan Head Screw #10 x 3/4"	4
-----	---------------------------	---

### Hardware Bag - Router Screws *See page 7 or Router Chart*

STD (STANDARD): 5/16-18 x 1/2" (4), 1/4-20 x 1/2" (4), 10-24 x 3/8" (3),  
8-32 x 5/16" (3), 10-32 x 1/2" (4)

MTR (METRIC): M6 x 1.00 x 12mm (3), M4 x 0.70 x 10mm (4),  
M4 x 0.70 x 6mm (4)

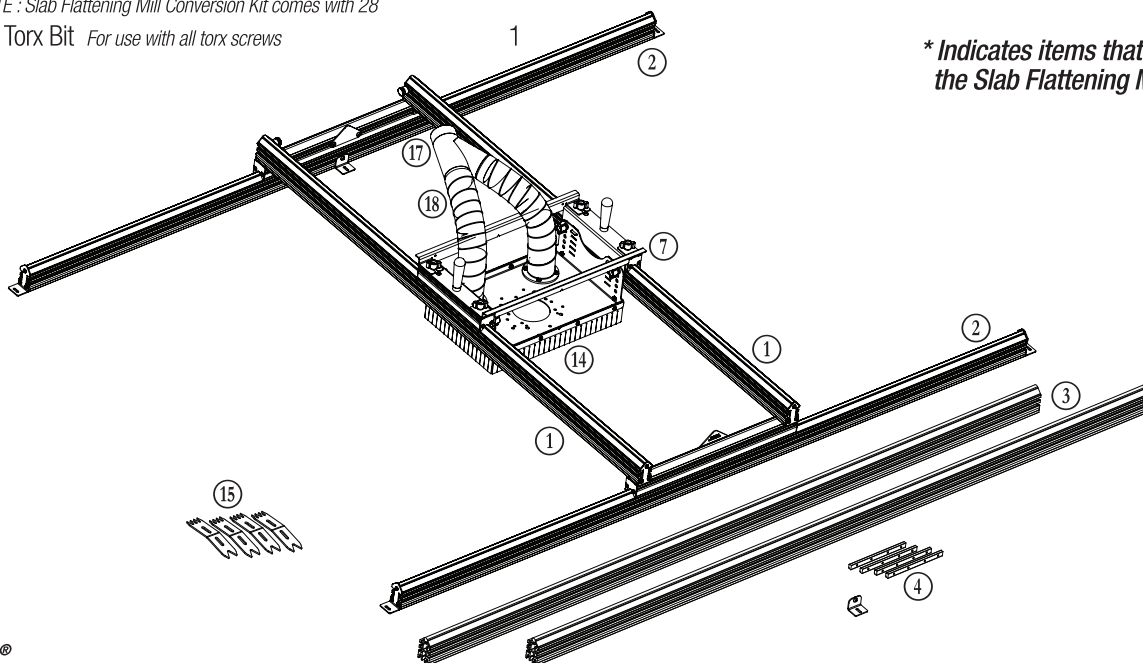

*\* Indicates items that are not included in the Slab Flattening Mill Conversion Kit.*

## I. INSTALL GLIDE STRIPS ON GUIDE BLOCKS

### AT THIS POINT YOU WILL NEED:

- ⑤ Short Guide Blocks (Red Anodized Aluminum) (2)
- ⑥ Long Guide Blocks (Red Anodized Aluminum) (2)
- ⑨ Roll of UHMW Tape

Cut eight 4" long strips from the roll of UHMW Tape. Peel the backing and apply the strips to the Long Guide Blocks. **Figure 1**. Align the edge of the UHMW Tape with the edge of the groove as shown below in **Detail 1-A**. Align the end of the UHMW Tape with the end of the Guide Blocks as shown below in **Figure 1-B**.

Cut eight 2" long strips from the roll of UHMW Tape. Peel the backing and apply the strips to the Short Guide Blocks, **Figure 1**. Align the edge of the UHMW Tape with the edge of the groove as shown below in **Detail 1-A**. Align the end of the UHMW Tape with the end of the Guide Blocks as shown below in **Detail 1-B**.

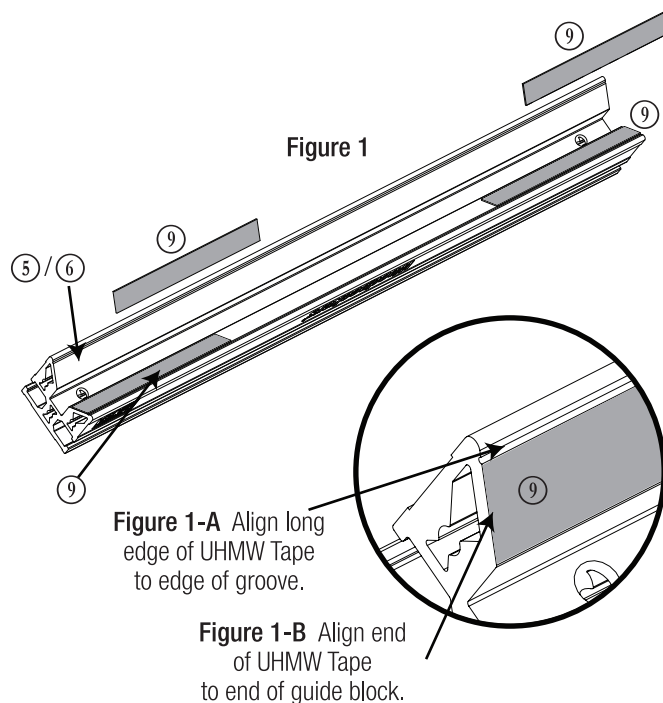

## II. CROSS-RAIL GUIDE BLOCKS

### AT THIS POINT YOU WILL NEED:

- D-1 Safety Stops (2)
- D-2 Button Head Hex Screw 1/4-20 x 5/8" (4)
- D-3 Nyloc Nut 1/4-20 (4)
- N-1 Guide Block End Caps (4)
- E-1 Torx Thread Forming Screw 10-32 x 1/2" (8)
- E-NA Torx Bit T25 x 1"
- K-1 Cross-Rail Gussets (4)
- I-1 Oval Nut 1/4-20 (8)
- B-1 Button Head Screw 1/4-20 x 1" (8)
- B-4 Nyloc Nut 1/4-20 (12)
- B-3 Button Head Hex Screw 1/4-20 x 5/8" (8)
- B-2 Button Head Hex Screw 1/4-20 x 1-1/2" (4)
- B-NA5/32" Hex Key *For use with all Hex Screws*

Loosely install two D-2 Button Head Screws and D-3 Nyloc Nuts in the D-1 Safety Stops with the Nuts opposite the printed side of the Safety Stop onto both of the Long Guide Blocks. **Figure 2-A**.

Slide the Safety Stop assembly into the track slot of the Long Guide Block (on the unprinted side). Move the Safety Stop assembly to the center of the Guide Block and tighten.

Loosely install two B-3 Button Head Screws and B-4 Nyloc Nuts in the smaller flange of the Cross-Rail Gussets with the Nuts on the outside of the Gusset fold. **Figure 2-B**.

Loosely install two B-1 Button Head Screws and I-1 Oval Nuts in the larger flange of the Cross-Rail Gussets with the Oval Nuts on the outside of the Gusset fold.

Install the Gusset assembly to the Long Guide Blocks by sliding the Nyloc Nuts into the track on the unprinted side (same as Safety Stops).

Install two B-2 Button Heads Screws up through the Long Guide Block. Loosely secure with two B-4 Nyloc Nuts.

Install the N-1 Guide Block End Caps with E-1 Torx Thread Forming Screws. **DO NOT use a power driver!** Tighten by hand with the supplied E-2 Torx bit in a hand-held driver. **Figure 2-C**.

Cross Rail Guide Block assembly should look like the drawing in **Figure 3**. **DO NOT tighten bolts at this time.**

Repeat these steps for other Long Guide Block.

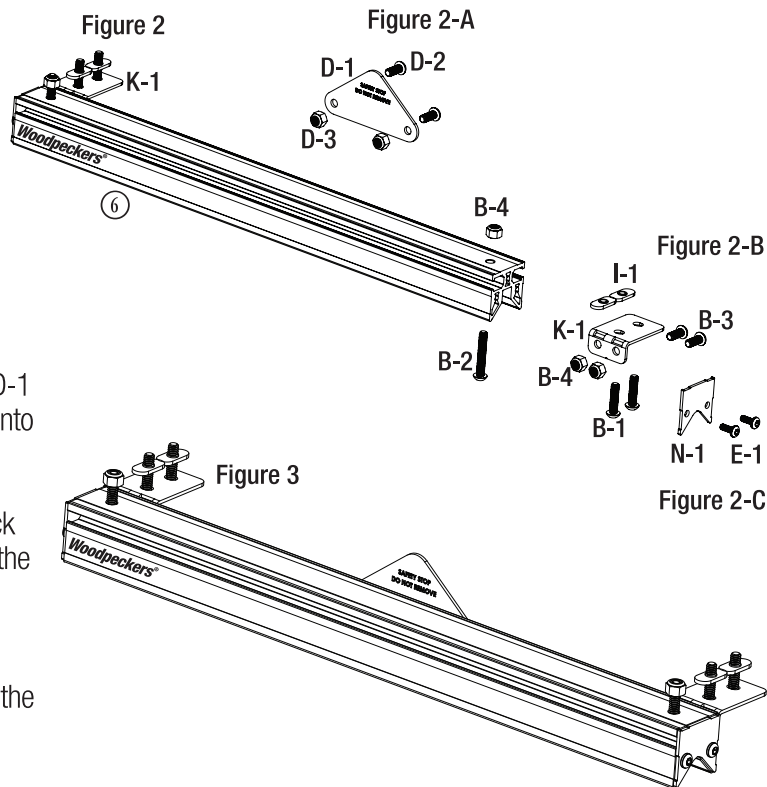

#### IV. CROSS RAIL ASSEMBLY

AT THIS POINT YOU WILL NEED:

- ① Short V-Rails (2)

Slide the Cross Rail Guide Blocks into both ends of both Short V-Rails with the Track Nuts sliding into the bottom groove of the V-Rails. *Figure 4.*

Use an accurate square to align one Guide Block to both V-Rails and tighten the screws **on that end only at this point**. You will secure the other end once the router carriage assembly is finished. *Figure 6.*

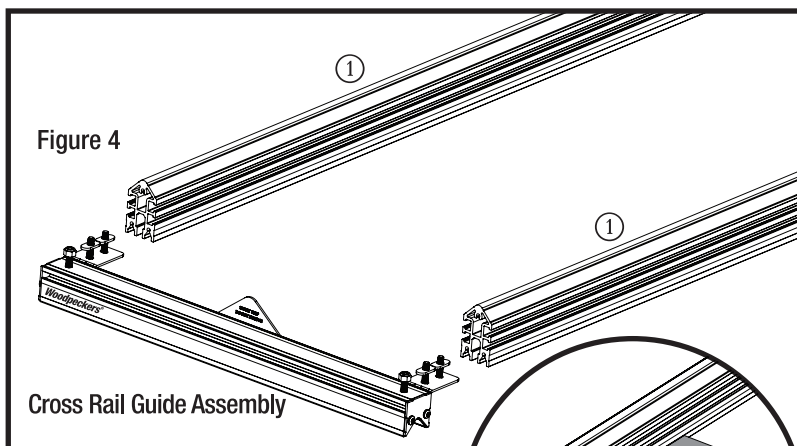

#### IMPORTANT NOTE

To deliver the most accurate results, your Slab Flattening Mill-PRO needs to be mounted to a surface that is well supported and flat in both directions. We recommend using a sheet of quality hardwood plywood or medium density fiberboard (MDF) resting on a workbench that supports the sheet nearly to its edges. If your workbench doesn't fully support your work surface, build a frame that extends support for the sheet. To verify that your surface is flat, adjust your workbench legs with shims so that the top is level in both directions, then check the work surface with a straight edge. Once you have the surface both level and flat, you're ready to assemble your Slab Flattening Mill-PRO Base.

#### V. MOUNT BASE RAILS

AT THIS POINT YOU WILL NEED:

- M-1 V-Rail Mounting End Cap (4)
- ② Long V-Rail 76" (2)
- E-1 Thread Forming Screw Pan Head 10-32 x 1/2" (12)
- O-1 Pan Head Screw #10 x 3/4" (4)
- J-1 Oval Nut 1/4-20 (1)
- J-2 Button Head Hex Screw 1/4-20 x 3/8" (1)
- J-3 V-Rail Center Support (1)
- J-4 Pan Head Screw #10 x 3/4" (1)

Install the M-1 V-Rail Mounting End Caps to both ends of both Long V-Rails using three E-1 Thread Forming Screws each side. *Figure 5/5-A.* Use a handheld screwdriver with the provided Torx bit to install the thread forming screws.

**NOTE: It is very easy to strip out the aluminum extrusion if you use a power driver.**

Install one Long V-Rail along one edge of your work surface using O-1 Pan Head Screws through the V-Rail Mounting End Caps. *Figure 6.*

Install a J-1 Oval Nut and J-2 Button Head Screw through one side of the J-3 V-Rail Center Support. Slide the Oval Nut down the track of the V-Rail to the middle of the V-Rail. Tighten the Button Head Screw and secure the V-Rail Center Support to your work surface with a J-4 Pan Head Screw. *Figure 6-B.*

For maximum width capacity, locate the second Long V-Rail 57-1/2" (center to center) from the first. If you're setting up on a narrower work surface, mount the second rail parallel to the first at your desired dimension. **Do not tighten the second V-Rail to the work surface at this time.** *Figure 6-A.*

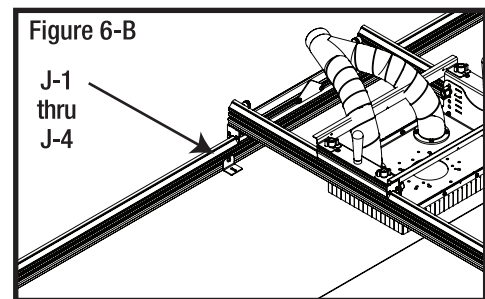
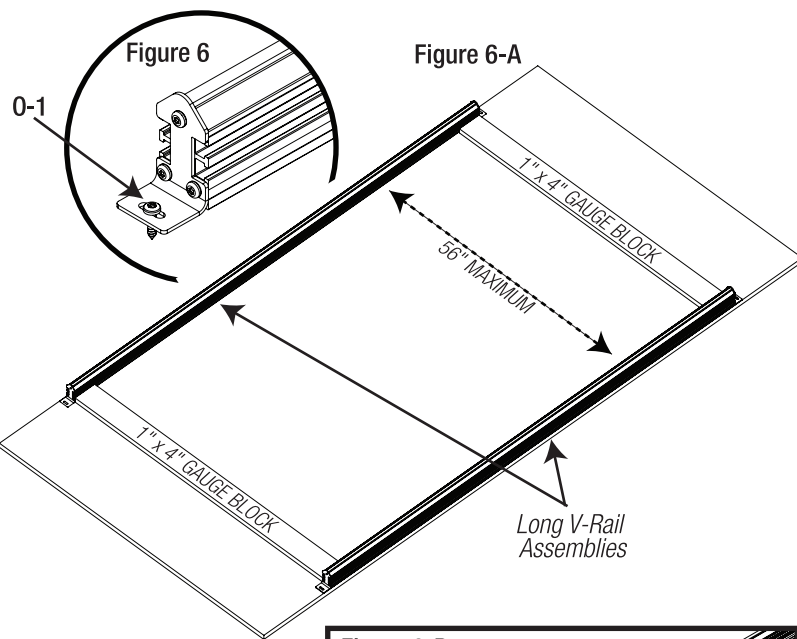
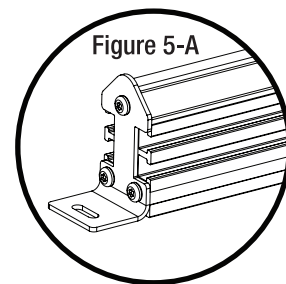
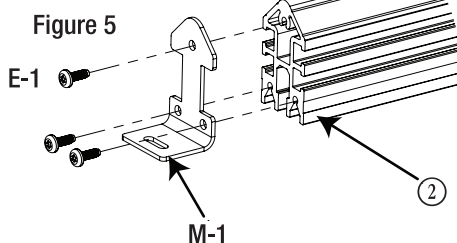



## VI. ROUTER CARRIAGE STAND

### AT THIS POINT YOU WILL NEED (NOT SUPPLIED):

- 3/4" x 3-1/2" x 8" Plywood or Hardwood (2)
- 3/4" x 3-1/2" x 12" Plywood or Hardwood (2)
- Fasteners - as needed

While assembling your Router Carriage you will need to support it off the table. In use, you'll need to support the Router Carriage any time it is not mounted on the rails to prevent damage to the Dust Curtain (and potentially your router bit). So, you should build this stand before starting the assembly procedure. Per **Figure 7**, build a box from 3/4" material 3-1/2" tall, 8" wide and 13-1/2" long.

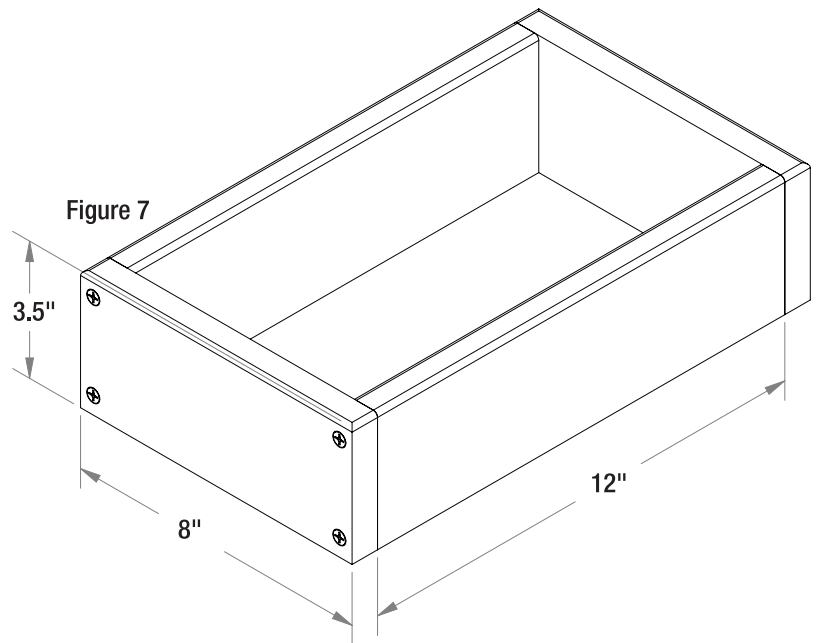

## VII. ROUTER CARRIAGE ASSEMBLY STEP 1

### AT THIS POINT YOU WILL NEED:

- ⑤ Short Guide Block (Red Anodized Aluminum) (2)
- ⑧ Router Carriage Hanger (2)
- ⑦ Router Carriage (1)
- H-1 Red Wing Knob 1/4-20 Nut (4)
- H-3 White Nylon Washer 3/4"OD (4)
- C-1 Button Head Hex Screw 1/4-20 x 1/2" (4)

Install the Router Carriage Hangers loosely on the Short Guide Blocks with C-1 Button Head Screws using the two inboard holes at each end. The threaded studs on the side should point away from the Guide Blocks as shown **Figure 8**. Tighten the Button Head Screws just less than finger-tight.

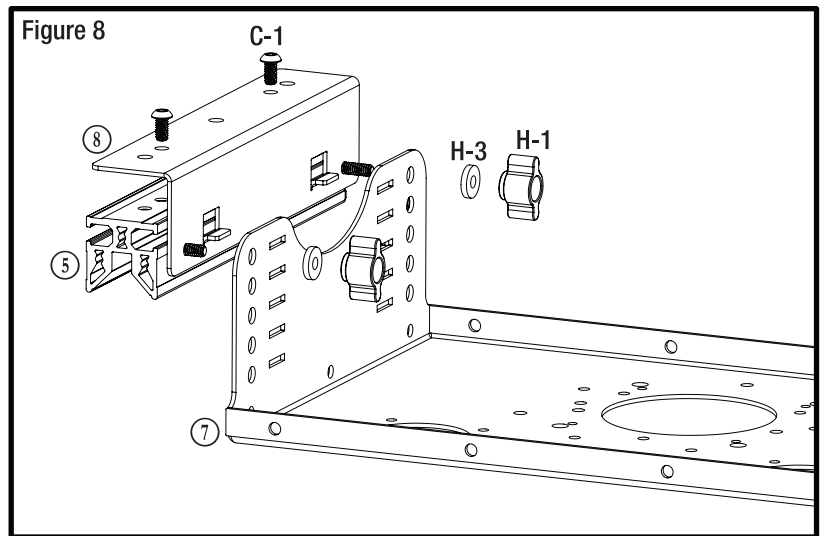

Slide the threaded studs and index pins of the Router Carriage Hangers through the highest set of holes in the Router Carriage. Place a H-3 White Nylon Washer on then secure with Female Wing Knobs.

Repeat these steps for the other side of the Carriage.

## VIII. RAIL & CARRIAGE ALIGNMENT

### AT THIS POINT YOU WILL NEED:

- N-1 Guide Block End Cap (4)
- L-1 V-Rail End Cap (4)
- E-1 Thread Forming Screw Pan Head 10-32 x 1/2" (20)

Set the Router Carriage Assembly on the squared and tightened end of the Cross Rail Assembly. Make sure the Carriage is fully seated on the index pins. Slide until the edge of the Router Carriage is fully butted against the Cross Rail Guide Block. Make sure the Router Carriage Assembly Guide Blocks sitting flat on the Cross Rail Assembly V-Rails with complete contact on the glide strips at each corner. When everything is flat, flush and square, lock the Router Carriage Hangers to the Guide Blocks. **Figure 9**.

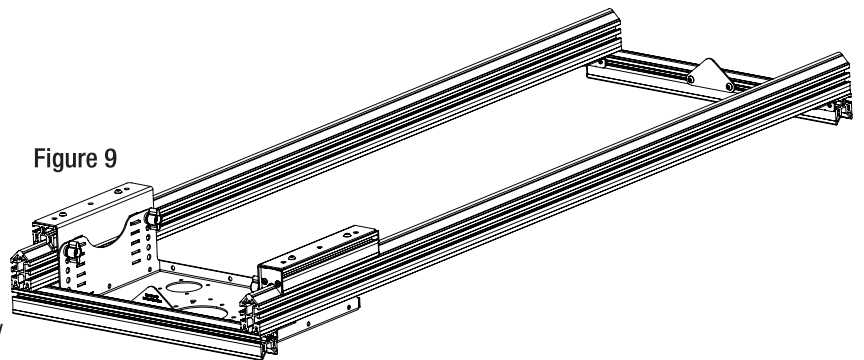

Now slide the Router Carriage Assembly to the other end of the Cross Rail Assembly. Ensure that the Router Carriage Assembly is resting flat on the V-Rails. If it is not, adjust the Cross Rail Assembly (which should not be tightened at this point). Once the Cross Rails are adjusted so the Router Carriage is sitting flush, lock the Cross Rails to the Guide Blocks.

Finally, set the Cross Rail assembly on the Base Rails. Slide to one end and adjust the loose Base Rail until the Cross Rail Assembly is setting perfectly on the Base Rails. Once properly aligned, lock that end of the loose Base Rail. Slide the Cross Rail Assembly to the other end and repeat the process.

Install the Guide Block End Caps and V-Rail End Caps with thread forming pan head screws. **DO NOT use a power driver!** Tighten by hand with the supplied Torx bit in a hand-held driver.

## IX. ROUTER CARRIAGE ASSEMBLY STEP 2

### AT THIS POINT YOU WILL NEED:

- ⑭ Short Vinyl Curtain (2)
- ⑬ Long Vinyl Curtain (2)
- ⑫ Short Curtain Retainer (2)
- ⑪ Long Curtain Retainer (2)
- ⑯ 2.5" Dust Port (2)
- ⑰ "Y" Hose Connector (1)
- ⑩ Cross Brace (2)
- A-1 Pan Head Screw 10-32 x 7/16" (22)
- A-2 Kep Nut 10-32 (22)
- ⑱ 2.5" Dust Hose (2)
- ⑲ Hose Clamps (2)
- F-1 Black Nylon Washer 3/4" (2)
- F-2 White Nylon Washer 3/4" (2)
- F-3 Oval Nut 1/4-20 (2)
- F-4 Black Knob 1/4-20 x 3/4" (2)
- H-2 Red Wing Knob with Threaded Extension 1/4-20 x 3/4" (4)
- G-1 Tapered Handle (2)
- G-2 Black Nylon Washer (2)
- G-3 Hex Head Bolt 1/4-20 x 1-1/2" (2)

Rest your partially assembled Router Carriage on the Router Carriage Stand you built (Step VI). Install the Short and Long Dust Curtains, sandwiching them between the side of the Router Carriage and the Short and Long Dust Curtain Retaining Strips. Secure with fourteen A-1 10-32 Pan Head Screws and A-2 Kep Nuts. **Figure 10.**

Slide G-3 1/4-20 x 1-1/2" Hex Head Bolts up through the Router Carriage Guide Blocks. Install a G-2 Black Nylon Washer and G-1 Tapered Handle to each one.

Loosely thread the H-3 Red Wing Knobs into the outboard holes on the Router Carriage Guide Blocks. Slide the notches on the 10 Cross-Braces under the knobs and tighten the knobs.

Install the two 2.5" Dust Ports with four A-1 10-32 Pan Head Screws and A-2 Kep Nuts.

Attach the two 2.5" Dust Hoses to the 2.5" Dust Ports and join them with the "Y" connector. Secure with two Hose Clamps. **Figure 11.**

**NOTE:** You may find it easier to install the hose if you trim the clear material down close to the ribs with a razor knife.

**Travel Stops** There are two travel stops that fit into the slots of the V-Rails of the Cross Rail Assembly. They can be used to lock the Router Carriage Assembly in position for edge routing and rabbetting operations. **Figure 11-A.**

To assemble the travel stop, slide the thick F-1 Black Washer and the F-2 White Nylon Washer on the F-4 Black Knob. Thread on the F-3 Oval Nut. Slide the Oval Nut in the track of the Cross Rail Assembly and tighten.

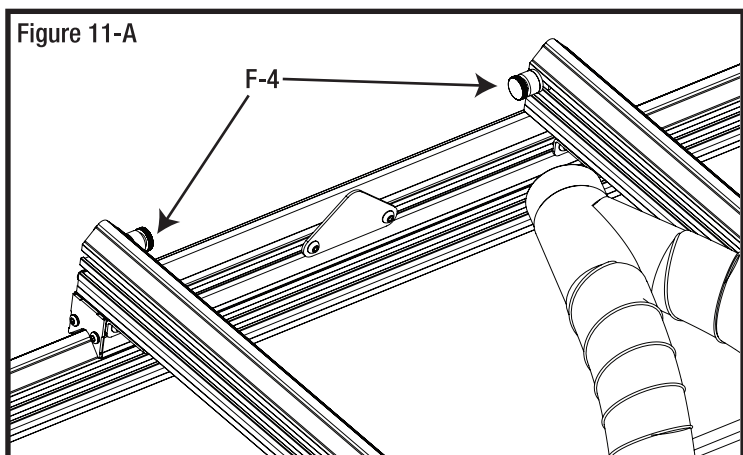
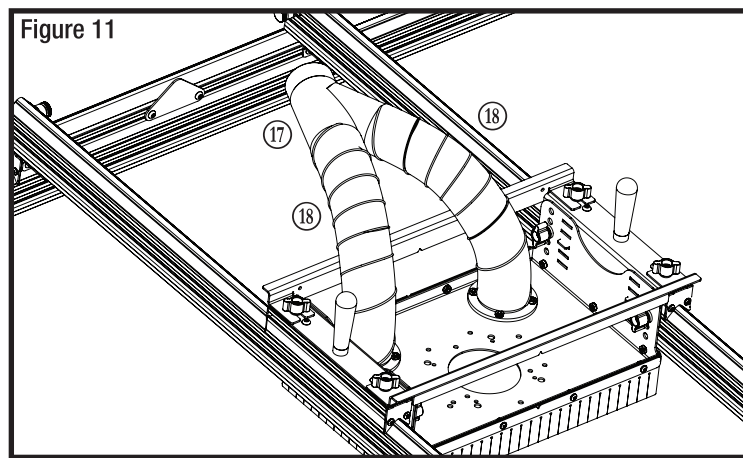
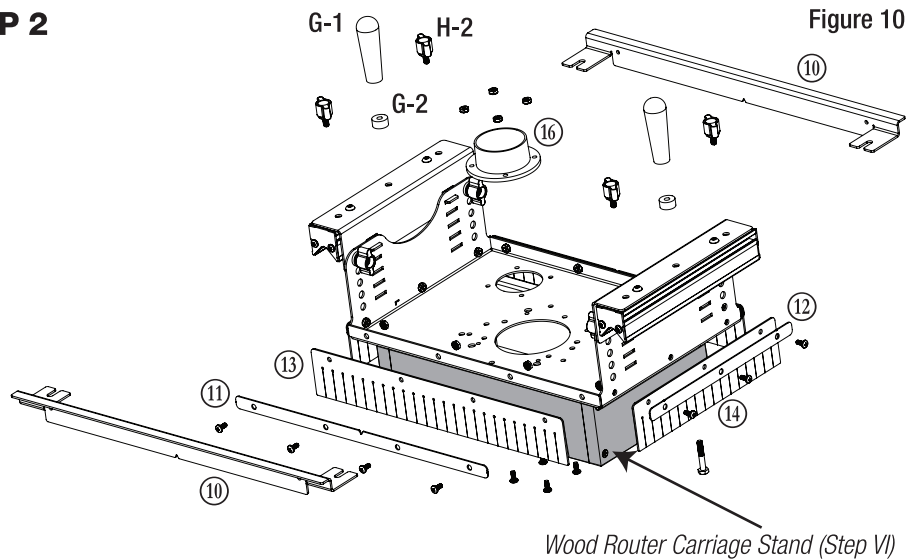

## X. MOUNT ROUTER TO ROUTER CARRIAGE

AT THIS POINT YOU WILL NEED:  
**HARDWARE BAG - ROUTER SCREWS**

STD (STANDARD): 5/16-18 x 1/2" (4), 1/4-20 x 1/2" (4), 10-24 x 3/8" (3), 8-32 x 5/16" (3), 10-32 x 1/2" (4)

MTR (METRIC): M6 x 1.00 x 12mm (3), M4 x 0.70 x 10mm (4), M4 x 0.70 x 6mm (4)

From the chart below, **Figure 12**, select the screws and hole pattern which matches your router. Remove the screws and the face plate from your router. Use the Router Screws provided to attach your router to the Router Plate ensuring that the handles on your router do not interfere with your grip on the Router Sled Handles.

**Figure 12 TOP VIEW OF ROUTER CARRIAGE**

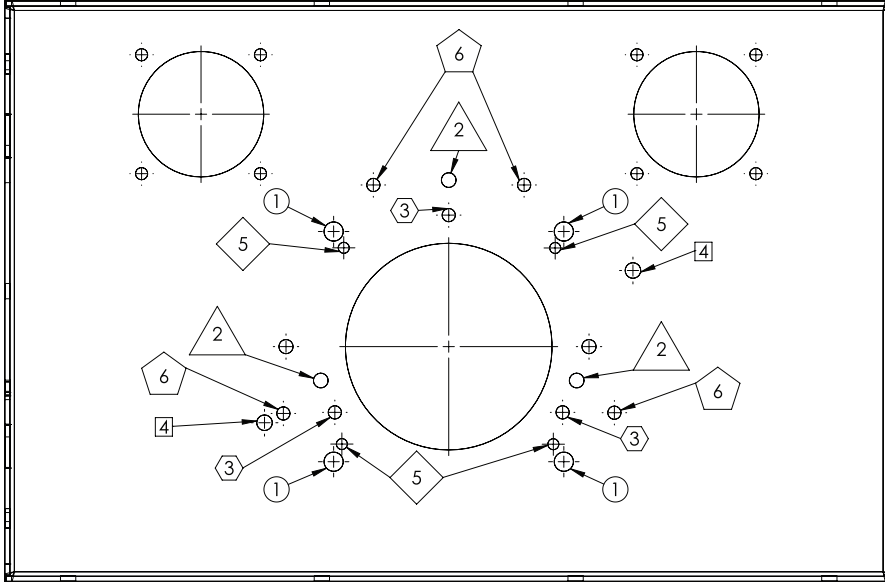

Compatible Router	Hole #	Screws	Qty
Porter Cable 7518/7519	1	5/16-18	4
Porter Cable 890	3	10-24	3
Festool 2200	4	M6 X 1.00	2
Triton TRA001	1	1/4-20	4
Tritan MOF001	1	1/4-20	4
Bosch 1617 EVS (Fixed base only)	3	10-24	3
Bosch MRC23EVSK	3	M4 X 0.7	3
Milwaukee 5625	1	5/16-18	4
Milwaukee 5616	3	10-24	3
DeWalt 618B3	3	8-32	3
DeWalt 625/621	2	M6 X 1.00	3
Makita RF1101	3	10-24	3
Makita RP2301FC	5	M4 X 0.7	4
Hitachi M12v2	6	10-32	4

## XI. ADJUSTING THE ROUTER CARRIAGE ASSEMBLY

The Router Carriage adjusts up and down to accommodate different thickness of slabs. To adjust the Router Carriage, begin by placing the Router Carriage on your shop-built stand. Loosen the knobs that secure the cross-brace and remove the cross-brace. Remove the four knobs that hold the Router Carriage to the Router Carriage Hangers. Adjust the Router Carriage Hangers to the appropriate position. Replace the knobs finger tight. Replace the cross-braces.

Set the Router Carriage Assembly on the Cross-Rail Assembly. Loosen the knobs that hold the Router Carriage to its hangers just less than finger tight. Make sure the Router Carriage tabs are bottoming out in the appropriate slots (same slots on both sides) and tighten firmly.

## SLAB FLATTENING MILL CONVERSION KIT

If you purchased the Slab Flattening Mill Conversion Kit you need to disassemble your Cross-Rail Assembly and re-use the V-Rails with the new Guide Blocks in your Conversion Kit, following the instructions in this manual. You can exclude Section V. as your mounted Base Rails should not need any changes.

NOTE: The V-Rail End Plates and the Guide Block End Plates will be reused.

## USING YOUR SLAB FLATTENING MILL-PRO

Remove the Router Carriage Assembly and Cross-Rail Assembly.  
*Figure 13.*

Position your slab roughly centered between the Long V-Rails and no closer than 9" from the ends. Typically, start by cutting what will be the bottom of the finished slab first.

Replace the Cross-Rail Assembly and Router Carriage Assembly.

Use the Router Carriage Assembly as a reference point to locate the high and low points on the slab. Shim the slab to eliminate rocking and to level out crowns and twists. There is some "art" involved in this step. Try to shim and brace the slab to maximize the finished thickness and minimize the amount of cutting you must do. When the slab is properly adjusted and stable, install the Slab Clamping Dogs. Put one screw behind the Slab Clamping Dog to position it, then a second through it to lock the slab in place. *Figure 14. Make sure the ends of the Slab Clamping Dogs are well below the cutting plane of the router bit.*

We recommend a "spoilboard" style router bit. Follow the router bit manufacturer's recommendations for router speed and depth of cut.

Set your router bit on the highest point in the slab. Adjust the depth of cut to remove a conservative amount from that point. It's a good idea to take a light cut and traverse the entire slab carefully to ensure you correctly identified to highest point.

Typically work from right to left, taking approximately one half the router bit width per pass, pushing the router across and back, then stepping to the left again.

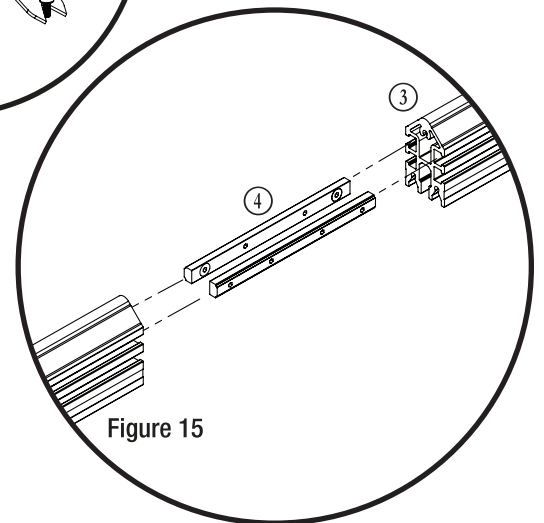
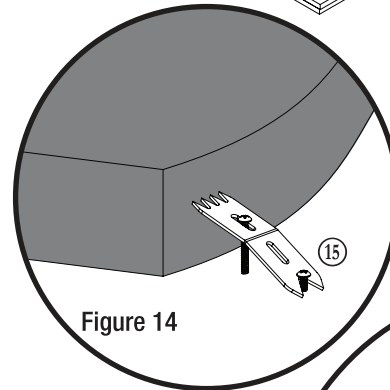
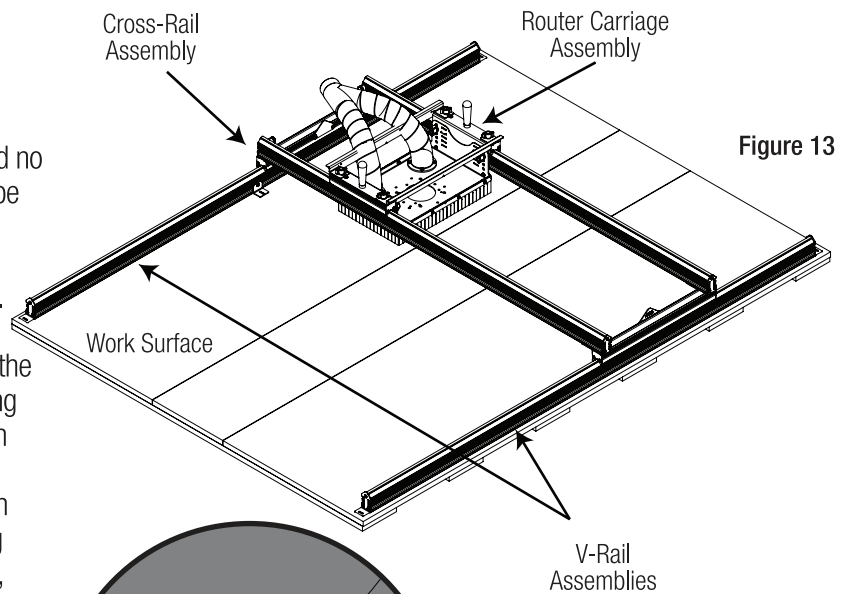

## NARROWER SLABS OPTIONAL

When working on narrow slabs, you may want to move one of the Long V-Rails closer. Use the same gauge block procedure outlined previously (*See Section V. Mount Base Rails, Page 4*). Once the Long V-Rails are parallel and screwed down, unlock the six machine screws (*See Figure 3 Section II. Cross-Rail Guide Blocks, Page 3*) that secure the end of the Cross-Rail Assembly and slide it in. Position both ends of the Cross Rail Assembly on the Long V-Rails, making sure the Long guide blocks are resting completely on the Long V-Rails, then re-tighten.

## LONGER OR WIDER SLABS OPTIONAL

The Long V-Rails can be repositioned down the length of a longer slab. Alternatively, you can extend the Long V-Rails with another pair of V-Rails and the V-Rail Connectors. *Figure 15. Use the connectors to extend the length of the main V-Rails only!* You can use the Long V-Rails in the Extension Kit to replace the Short V-Rails in the Carriage Assembly, but, **DO NOT use connected V-rails in the Cross-Rail Assembly.**

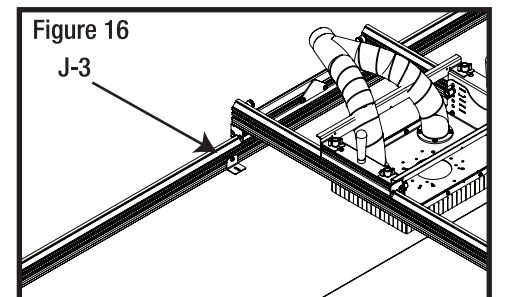

The V-Rail Extensions include a second J-3 V-Rail Center Support and related hardware. Install it in the middle of the extension Base V-Rail on the same side as on the original Base V-Rail. *Figure 16.*

**Woodpeckers®**

PRECISION WOODWORKING TOOLS  
Woodpeckers, LLC Strongsville, Ohio · [woodpeck.com](http://woodpeck.com)

© 2021 Woodpeckers, LLC



**WARNING!** This product can expose you to chemicals, including chromium, which is known to the State of California to cause cancer and birth defects or other reproductive harm. For more information go to [www.P65Warnings.ca.gov](http://www.P65Warnings.ca.gov)